



Customer Service  
 TEL: (954) 735-9800 Hours 9:00 a.m. - 5:00 p.m. EST. Monday-Friday  
 FAX: (954) 735-0642 www.pridefamilybrands.com

Prior to assembly please check that this package contains all parts as listed below.  
**NOTE:** If there are any missing parts or assembly difficulties, please contact us immediately.  
 Do not return product to store where purchased.

**IMPORTANT: HAND TIGHTEN ALL HARDWARE "ONLY" UNTIL FINAL ASSEMBLY IS COMPLETE . THEN FULLY TIGHTEN WITH THE INCLUDED TOOLS .**

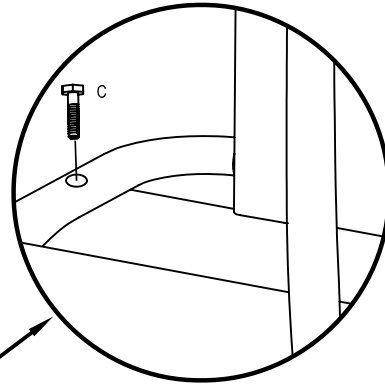
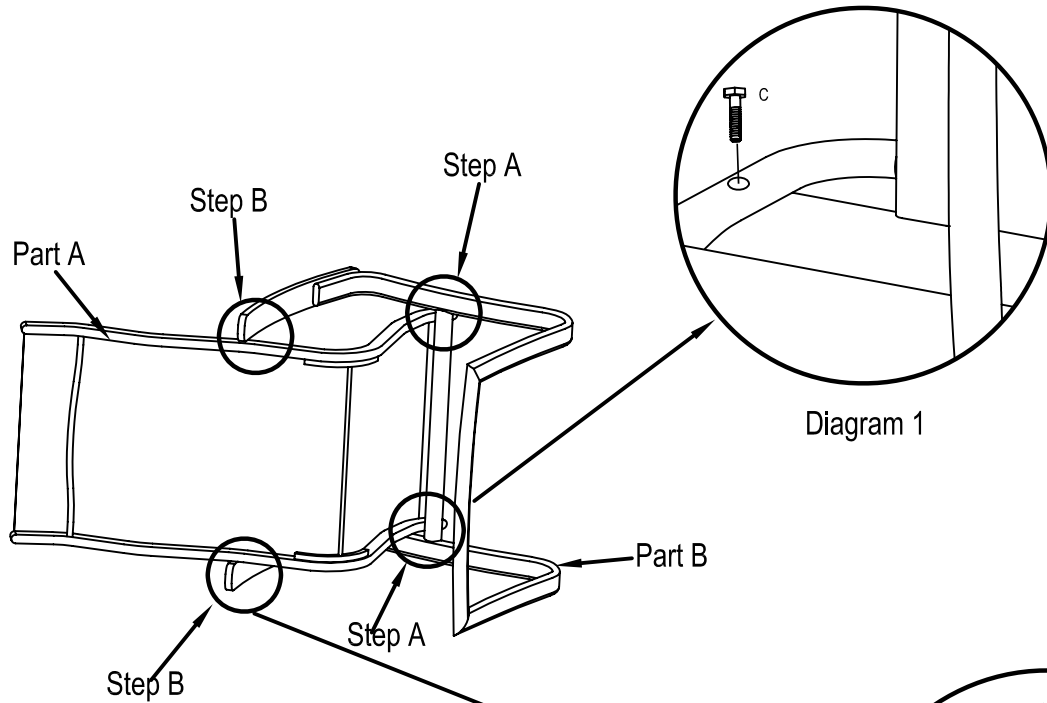

Diagram 1

Step 1: Hand tighten 4 bolts (part C) connecting the chair frame (part A) to chair base (part B). If necessary, adjust the chair base (part B) so that the holes in the chair frame (part A) line up and the screws are straight before you hand tighten them. This may require 2 people.  
 Step 2: Use wrench (part D) to fully tighten the screws. It is recommended to first tighten screws in diagram 1 step "A". Then to finally tighten screws in diagram 2 step "B" last.

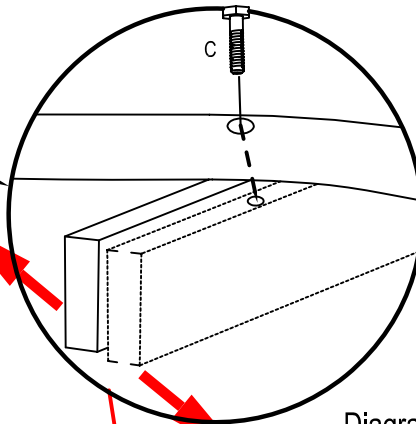
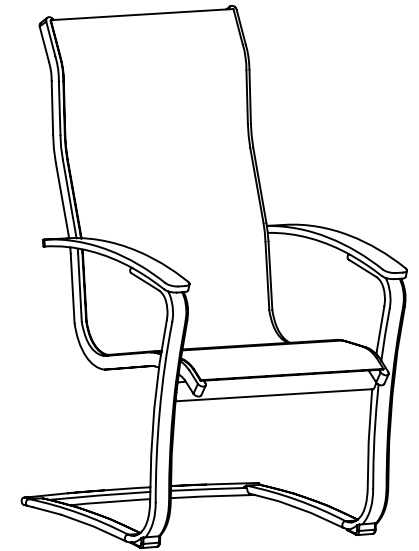

Diagram 2

Chair base can be adjusted slightly to line up with the hole in the chair frame.

**ASSEMBLY PARTS**

PART#	A	B	C	D
DESC.				
	CHAIR FRAME	CHAIR BASE	1/4"x35mm BOLT	WRENCH
QTY	1PC	1PC	4PCS	1PC



**ASSEMBLY INSTRUCTION  
 ITEM # R6341S  
 MADE IN CHINA**