



Assembly Instructions
Model: SQT42

- (1) Hardware pack
- (4) Legs
- (2) Braces
- (2) Foot
- (1) Table top

Step 1
 Attach feet to legs using
 (4) 1/4x3" Lag bolts and washers

Attach braces to legs using
 (4) 3" chair screws

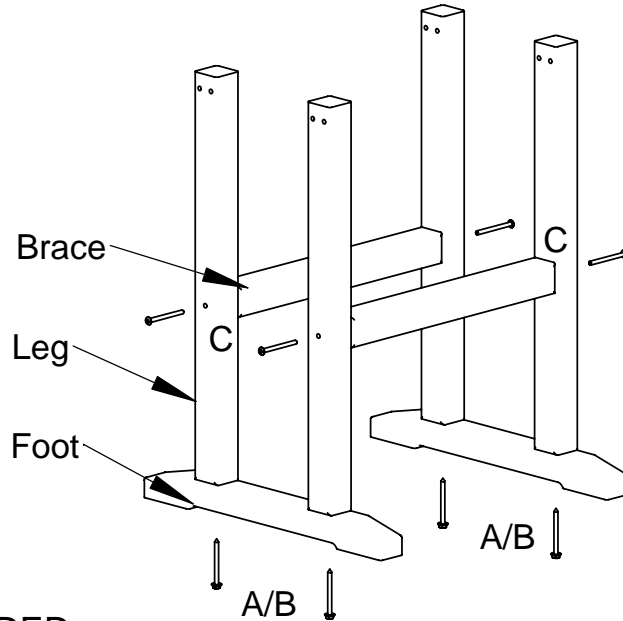

Step 2
 Lay table top on flat surface
 Attach leg assembly to table top using
 (8) 1/4x3" Lag bolts and washers

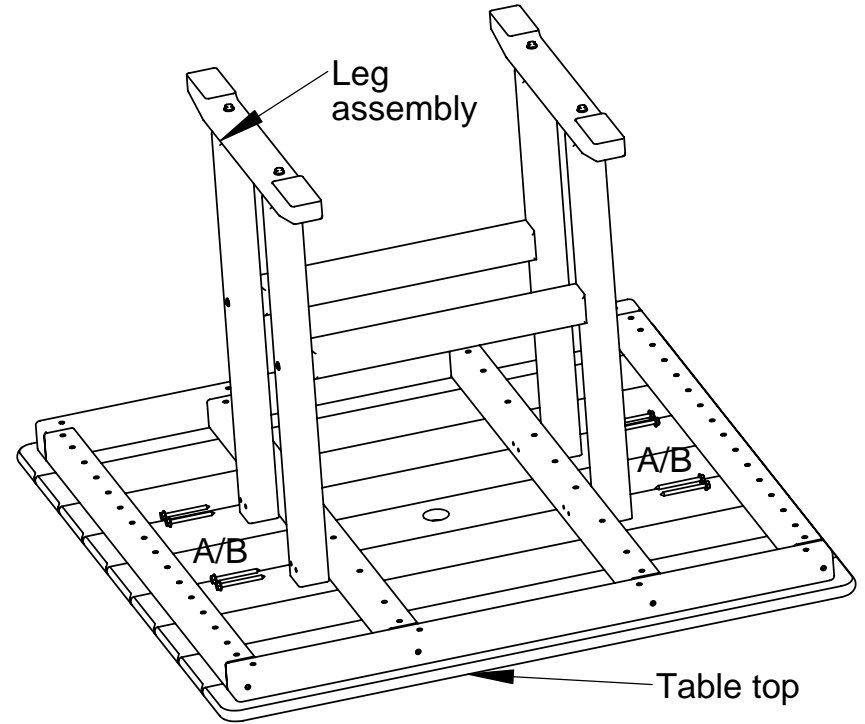

TOOLS NEEDED

7/16 Socket or Wrench
 5/32" HEX KEY: INCLUDED

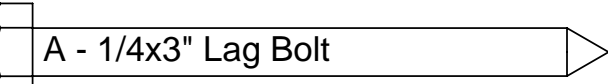
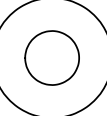
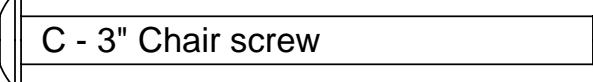
Qty.	Description
1	 Hole plug
12	 A - 1/4x3" Lag Bolt
12	 B - 1/4" washer
4	 C - 3" Chair screw

All bolts are 1/4