



Assembly Instructions

Model: SQ42 & SQ33

Step 1

Place table top upside down on a flat surface
 Align legs on table top using the identification lables (A,B,C,D)
 Attach the leg assemblies to table top using (8) 3/12" truss bolts
 nuts and washers in pre-drilled holes (A)
 Do not tighten any screws or bolts until end.

Step 2

Attach the angle braces to the leg assemblies using
 (4) 1 1/2" screws in pre-drilled holes (B)

Step 3

Attach leg assemblies to table top using
 (8) 2" screws (C)

Flip table over and tighten all bolts and screws at this time

- (1) Table top
- (4) Leg assembly
- (1) Hardware pack

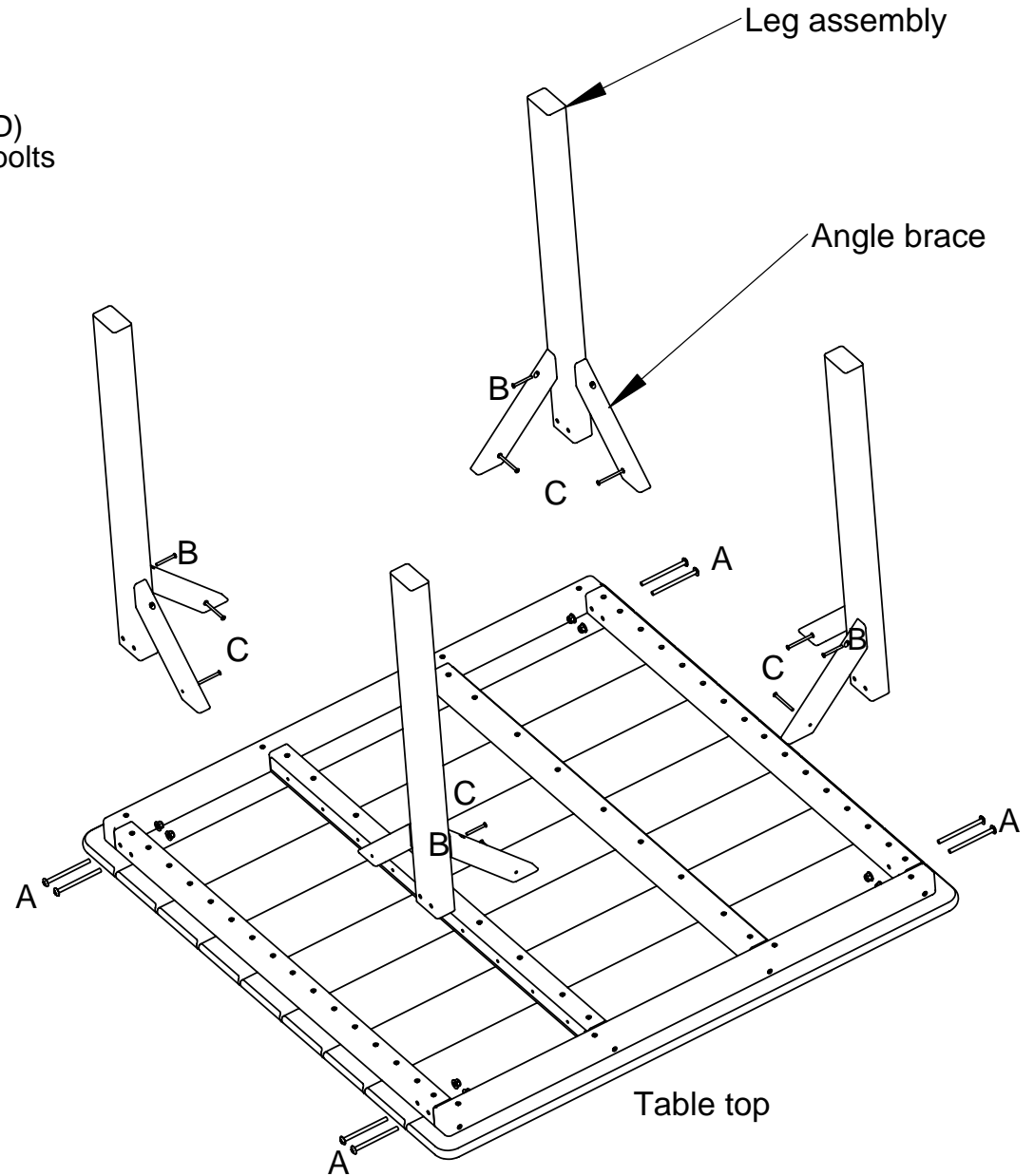

Qty.	Description
8	A - 3 1/2" Truss bolt
8	A - 1/4" washer
8	A - 1/4-20 nut
4	B - 1 1/2" screw
8	C - 2" screw

TOOLS NEEDED

Phillips head screwdriver
 Screw gun is required
 7/16 wrench or socket